



Occurrence, fate and risk assessment of androgens in ten wastewater treatment plants and receiving rivers of South China



Jin-Na Zhang^{a, e}, Guang-Guo Ying^{a, b, *}, Yuan-Yuan Yang^a, Wang-Rong Liu^c,
Shuang-Shuang Liu^d, Jun Chen^b, You-Sheng Liu^a, Jian-Liang Zhao^a, Qian-Qian Zhang^a

^a State Key Laboratory of Organic Geochemistry, Guangzhou Institute of Geochemistry, Chinese Academy of Sciences, Guangzhou, 510640, China

^b The Environmental Research Institute, MOE Key Laboratory of Environmental Theoretical Chemistry, South China Normal University, Guangzhou, 510006, China

^c South China Institute of Environmental Sciences, Ministry of Environmental Protection of PRC, Guangzhou, 510655, China

^d Institute of Environmental Health and Pollution Control, School of Environmental Science and Engineering, Guangdong University of Technology, Guangzhou, 510006, China

^e The University of Chinese Academy of Sciences, Beijing, 100049, China

HIGHLIGHTS

- We investigated 14 androgens in 10 WWTPs and receiving rivers in South China.
- High removal efficiencies of androgens were observed in the WWTPs.
- The androgen removal attributed to biological degradation/transformation processes.
- Androgens detected in the receiving rivers showed high risks.

GRAPHICAL ABSTRACT

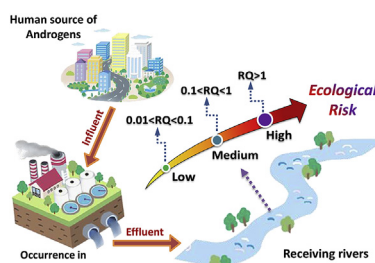

ARTICLE INFO

Article history:

Received 11 December 2017

Received in revised form

20 February 2018

Accepted 23 February 2018

Available online 26 February 2018

Handling Editor: Klaus Kummerer

Keywords:

Androgens
Removal
Mass balance
Risk assessment
Wastewater treatment plants

ABSTRACT

Androgens are one class of steroids that could cause endocrine disrupting effects in aquatic organisms. However, little information is available about androgens in wastewater treatment plants (WWTPs) with different treatment technologies. Here we investigated the occurrence, removal, and fate of fourteen natural and synthetic androgens in ten WWTPs of Guangdong province, south China. The results showed detection of ten androgens in the influents of the ten WWTPs, with concentrations up to 4650 ng/L (androsta-1,4-diene-3,17-dione). But only three androgens androsta-1,4-diene-3,17-dione, 4-androstene-3,17-dione and 17 β -boldenone were detected in the final effluents of the ten WWTPs, while six androgens androsta-1,4-diene-3,17-dione (N.D. to 43.0 ng/g), 4-androstene-3,17-dione (2.06–42.7 ng/g), epi-androsterone (N.D. to 506 ng/g), testosterone (0.29–4.24 ng/g), 17 β -boldenone (N.D. to 2.05 ng/g) and methyl testosterone (N.D. to 0.70 ng/g) were found in activated sludge. The aqueous phase removal rates for most androgens in the WWTPs exceeded 95% except for 4-androstene-3,17-dione with its removal rates varying between 79.5% and 100%. The removal of androgens in the WWTPs could be attributed mainly to biodegradation while removal by precipitation, volatilization, sludge absorption and oxidation was very limited. Eight androgens were also found in five receiving rivers. The risk quotients of some androgens (androsta-1,4-diene-3,17-dione, 4-androstene-3,17-dione, methyl testosterone, 17 α -

* Corresponding author. State Key Laboratory of Organic Geochemistry, Guangzhou Institute of Geochemistry, Chinese Academy of Sciences, Guangzhou, 510640, China.

E-mail address: guangguo.ying@m.scnu.edu.cn (G.-G. Ying).

trenbolone) exceeded 1 in the receiving rivers, showing high risks to aquatic organisms. Further studies are needed to understand the origin of these high risk androgens and ecological effects.

© 2018 Published by Elsevier Ltd.

1. Introduction

Steroid hormones include natural and synthetic steroid hormones and are regarded as endocrine disrupting chemicals (EDCs) (Ying et al., 2002). Comparing to other EDCs, steroid hormones often have greater endocrine disrupting effects since they may cause damages to living organisms at concentrations as low as 0.1 ng/L (Christiansen et al., 1998; Tyler et al., 1998). Numerous studies indicate that some human diseases and animal aberrations such as developmental defects, and reproductive disorders of some species may be related to the interference of environmental steroid hormones, which has aroused widespread concerns (Golden et al., 1998; Pelley, 2003; Tyler et al., 1998). There have been many studies on steroids in the environment, and mainly focused on estrogenic substances (Combalbert and Hernandez-Raquet, 2010; Fernandez et al., 2008; Ternes et al., 1999a, 1999b; Ying et al., 2002). The potential environmental hazards of other steroid hormones like androgens should also be attached importance since their environmental levels have been reported to be much higher than those of estrogens (Laurence and Mordechai, 2003; Liu et al., 2012b). Thus it is necessary to further investigate the contamination and potential effects of androgens.

Androgens have been reported with concentrations up to 133 ng/L for epi-androsterone in wastewater treatment plant (WWTP) effluents (Chang et al., 2011; Fan et al., 2011; Liu et al., 2012a; Leusch et al., 2014), and up to 214 ng/L for testosterone in surface waters (Chang et al., 2008, 2009; Kolpin et al., 2002; Vulliet et al., 2011). These androgens in the aquatic environments may pose risks to aquatic organisms. It was reported that trenbolone, a hormone used in cattle production, could reduce the N-acetylglucosaminidase activities of microbial communities in the sediment from a lake of Southern Germany significantly (Radl et al., 2005). Long-term exposure to water containing testosterone could decrease spawning rate and reproductive capacity of *Daphnia magna* (Barbosa et al., 2008). Long-term exposure (180 d) to androstenedione could induce masculinization in female mosquitofish (Hou et al., 2018). Exposure to methyl testosterone may inhibit gonadal development and reduced reproductive capacity of medaka (Kang et al., 2008). Endocrine disrupting effects on fish in rivers have been linked to the presence of some androgens. Elongation of anal fin in female mosquitofish has been observed in effluent-impacted streams in Canada and China (Jenkins et al., 2001; Huang et al., 2016). Orlando et al. (2004) found masculinization of female fathead minnows captured at river receiving feedlot drainage, and later Soto et al. (2003) detected significant androgenic activity at the same sites, indicating that the masculinization of female fish could be a consequence of androgen exposure. Some laboratory studies revealed that exposure to some steroid androgens (e.g. 17 α -methyltestosterone, testosterone propionate, 17 β -trenbolone) would bring adverse impacts on mammals, altering neuronal function in the forebrain (Penatti et al., 2009), causing abnormality of reproductive tissues and masculinization of offspring (Hotchkiss et al., 2007; Hotchkiss and Nelson, 2007). Although the environmental androgens may cause adverse effects, the monitoring data for androgens especially for synthetic androgens in WWTPs and surface waters are still very limited.

The objective of this study was to investigate the occurrence and

fate of 14 natural and synthetic androgens in ten WWTPs and their receiving rivers of Guangdong, China. A mass balance analysis was performed to assess the fate and removal mechanism for androgens in WWTPs. In addition, the potential ecological risks were assessed based on simple risk quotients.

2. Materials and methods

2.1. Chemicals

Fourteen steroid androgens were selected as the target compounds, including six natural androgens: 4-Androstene-3,17-dione (also known as Androstenedione, AED), Androsta-1,4-diene-3,17-dione (also known as Androstadienedione, ADD), Androsterone (ADS), 5 α -Dihydrotestosterone (5 α -DHT), Epi-androsterone (EADR) and Testosterone (TTR), and eight synthetic androgens: 17 α -Boldenone (17 α -BOL), 17 β -Boldenone (17 β -BOL), 4-Hydroxy-androst-4-ene-17-dione (4-OHA), Methyl testosterone (MT), 19-Nortestosterone (19-NT), 17 α -Trenbolone (17 α -TBL), 17 β -Trenbolone (17 β -TBL) and Stanozolol (S). Their basic physicochemical properties and other related information are given in Table S1, while chemical structures in Fig. S1 (Supporting Information SI). Testosterone-d3 and Stanozolol-d3 were used as the internal standards. All chemicals used in this study were purchased from reliable suppliers (SI Table S1).

2.2. Sampling sites and sample collection

Ten WWTPs with different treatment technologies were selected for this study and they are located in Guangdong province, South China (Fig. 1). The basic information of each WWTP is given in Table 1. Different sewage treatment technologies used in the ten WWTPs include: Carrousel 2000 Oxidation ditch, MBR (Membrane Bio-Reactor), modified A/O (Anaerobic-Oxic), A²/O (Anaerobic-Anoxic-Oxic), reversed A²/O, modified A²/O, and UNITANK (Alternating biological treatment process). The process flow charts and sampling sites are shown in Fig. 2. Wastewater samples were collected from every process unit, while activated sludge samples were collected from the biochemical stages, excess sludge and returned sludge. Besides, surface water and sediment samples from the upstream/downstream of the receiving rivers (100 m away from the effluent outfall) were also collected.

All the samples in three replicates were obtained during May to October 2015. Samples from the WWTPs were collected in 1 L amber glass as 24 h composite, while the samples from receiving rivers were collected as grab samples in the middle of the day. All water samples (1 L each) were added with 5% (v/v) of methanol to suppress microbial activities, and pH value was adjusted to 4 with 4 M H₂SO₄. For sludge and sediment samples, 1 g of NaN₃ was added into each sample to inhibit microbial activities. The collected samples were put in coolers and transported back to laboratory and then stored at 4 °C in the dark prior to further processing. The water samples were processed within 48 h, while the solid samples were freeze dried, grinded, and sifted by a 0.83 mm mesh, and then stored at 4 °C before extraction.

The basic quality parameters of water samples such as chemical oxygen demand (COD), biochemical oxygen demand (BOD₅),

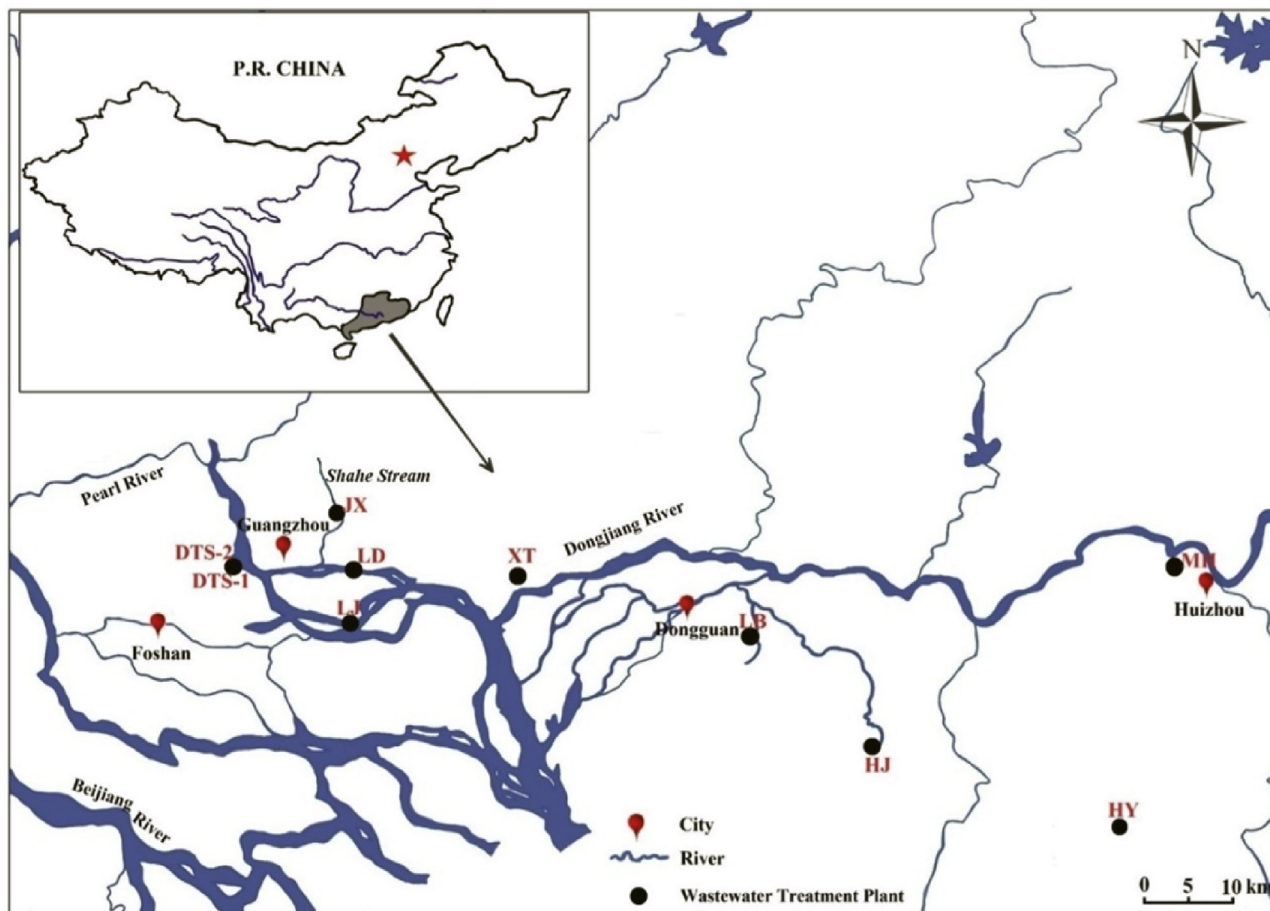

Fig. 1. Location map for the ten wastewater treatment plants (WWTPs) in South China.

Table 1
The basic information of ten municipal wastewater treatment plants.

Plant code	City	Process type	Average flow (m ³ /d)	Population served (Ten thousand)	Disinfection method	Hydraulic retention time (h)	TSS (mg/L)	Excess sludge		Receiving river
								Daily production (t/d, wet weight)	Moisture content (%)	
LB	Dongguan	A ² /O ^a	110000	30	UV	13.5	3600	34	78	Hanxi River
DTS-1	Guangzhou	A ² /O	165000	42.8	Cl	12	3500	45	80	Pearl River
DTS-2	Guangzhou	Reversed A ² /O	220000	57	Cl	12.5	4000	60	80	Pearl River
HY	Huizhou	Reversed A ² /O	76000	42.5	Cl	12	3000	35	78	Danao River
MH	Huizhou	Reversed A ² /O	88000	38	UV + Cl	12	3000	30	75	Dongjiang River
XT	Guangzhou	Modified A ² /O	107000	41	UV + Cl	12.5	3500	50	80	Dongjiang River
LJ	Guangzhou	Modified A/O ^b	200000	54	Cl	10	3600	48	78	Pearl River
JX	Guangzhou	MBR ^c	100000	13	UV	9.5	6000	36	76	Shahe stream
HJ	Dongguan	Carrousel 2000 Oxidation ditch	47000	13	UV	11	3100	15	80	Huangjiang River
LD	Guangzhou	UNITANK ^d	220000	39	Cl	13	3000	47	77	Pearl River

^a A²/O, Anaerobic-Anoxic-Oxic.

^b A/O, Anaerobic-Oxic.

^c MBR, Membrane Bio-Reactor.

^d UNITANK, Alternating biological treatment process.

ammonia-nitrogen (NH₃-N), total nitrogen (TN) and total phosphorus (TP) were measured for influent, effluent, and surface water using the standard methods (Clesceri et al., 2001), while other parameters such as pH, conductivity and dissolved oxygen (DO) were monitored by a multi-parameter water quality monitor (YSI-

Pro2030, YSI Incorporated, USA). Sludge and sediment samples needs to be pre-treated before using the similar methods of water samples to test their TP, TN and NH₃-N values. The total organic carbon (TOC) was analyzed by a TOC analyzer (LiquiTOC, Elementar Analysensysteme Co., Germany). More detailed information can be

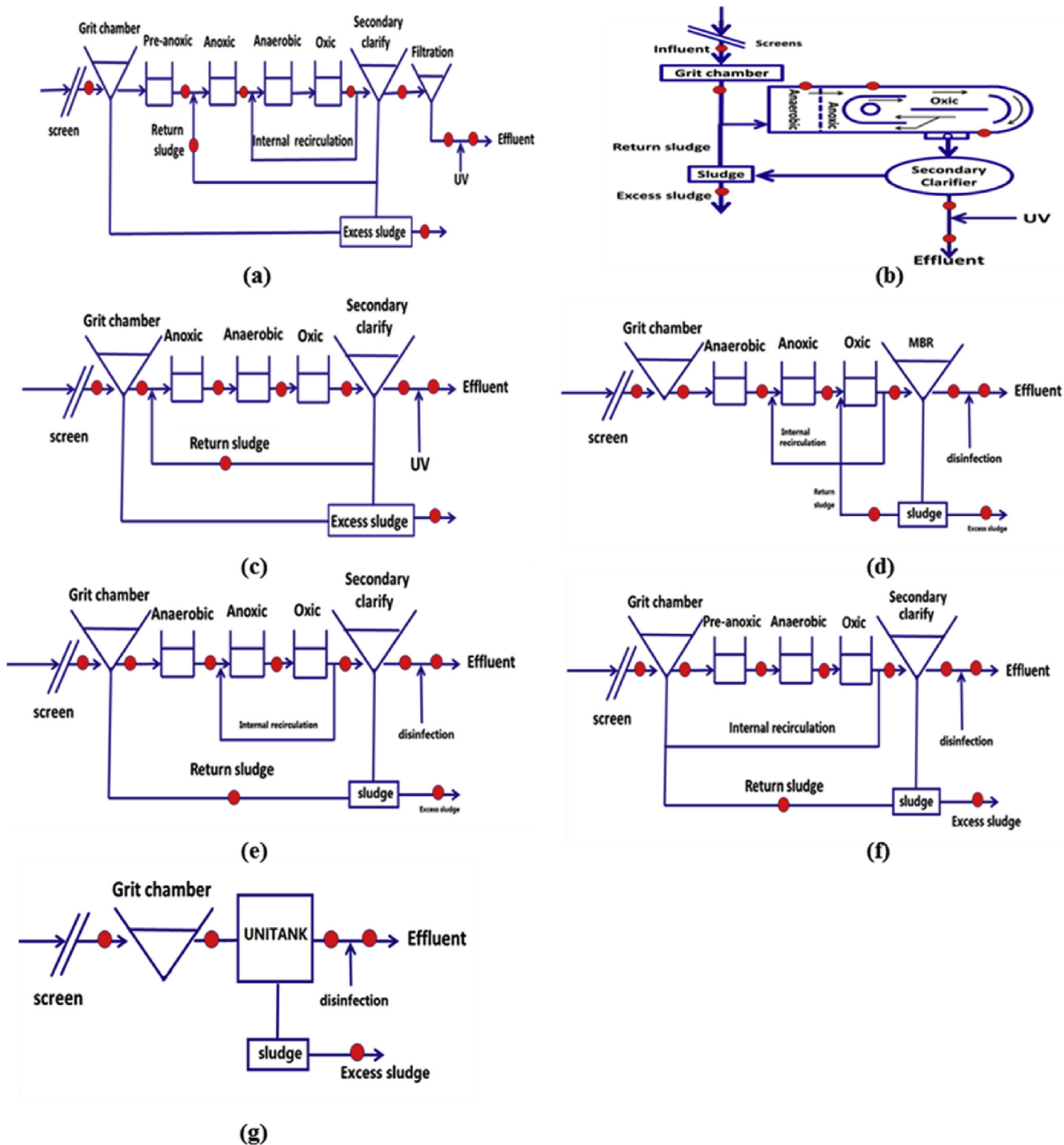

Fig. 2. Flow charts of technological processes and sampling sites for 10 WWTPs: (a) XT, Modified A²/O; (b) HJ, Carrousel 2000 Oxidation ditch; (c) MH, HY, DTS-2: Reversed A²/O; (d) JX: MBR; (e) LB, DTS-1: A²/O; (f) LJ: Modified A/O; (g) LD: UNITANK.

found in Table S2 and Table S3.

2.3. Sample extraction and instrumental analysis

Fourteen target androgens in all collected samples were extracted and analyzed according to our previous method (Liu et al., 2011). Briefly, water samples (1 L each) were filtered and spiked with 100 ng/L internal standard mixture, then extracted by solid-phase extraction (SPE) using Waters Oasis HLB cartridges (500 mg, 6 mL). The cartridges were dried and eluted each with

12 mL of ethyl acetate after SPE process, the eluents were then dried under a gentle nitrogen stream, and re-dissolved each with 1 mL of methanol and finally stored in a 2 mL amber glass vial after filtering through a 0.22 mm membrane filter. Sludge and sediment samples (0.5 g each) were freeze-dried, homogenized and spiked with internal standard mixture, then centrifuged after ultra-sonication extraction with ethyl acetate as the extracting solution; the ultra-sonication extraction and centrifugation were repeated three times. The supernatants were concentrated by rotary evaporation, then re-dissolved each with 1 mL of methanol and

finally stored in a 2 mL amber glass vial after filtering through a 0.22 mm membrane filter. All extracts were analyzed by ultra-high liquid chromatography-tandem mass spectrometry (UHPLC-MS/MS) after further purifying by self-made silica gel columns.

An Agilent 1200 LC-Agilent 6460 QQQ with electrospray ionization (ESI) source was applied to analyze the target androgens. The chromatographic separation was performed on an Agilent Zorbax SB-C18 (100 mm × 3 mm, 1.8 mm) column with its corresponding pre-column filter (2.1 mm, 0.2 mm). The column oven temperature was set to 40 °C and the injection volume was 10 µL. The mobile phase consisted of (A) an ultrapure aqueous solution containing 5 mM ammonium acetate and 0.05% formic acid (v/v) and (B) methanol. A gradient elution program with a flow rate of 0.35 mL/min was applied for detecting androgens. Mass spectrometry was performed using an Agilent 6460 Triple Quadrupole detector which was operated with ESI in positive mode. The quantitative analysis of the target compounds was performed in multiple reactions monitoring (MRM) mode. The recoveries of surface water, influent, effluent and sludge samples were 90.6–119.0% (except 5α-DHT was 143%), 44.0–200%, 60.7–123%, and 62.6–138%, respectively. The method detection limits for the 14 androgens in surface water, influent, effluent, freeze-dried sludge samples were 0.01–0.24 ng/L, 0.02–1.44 ng/L, 0.01–0.49 ng/L, and 0.08–2.06 ng/g, respectively (Liu et al., 2011). More details of extraction steps and instrumental conditions can be found in our previous work and SI.

2.4. Mass balance analysis

The mass balance analysis is mainly used to estimate the amounts of each target compound that enter and leave the wastewater treatment plants in the form of wastewater and sludge. Due to the low volatility of steroid hormones, the amount of hormonal volatiles entering the air can be considered as negligible. The basic mass balance equation is as following (Heidler and Halden, 2008):

$$M_{\text{Inf}} = M_{\text{Eff}} + M_{\text{Sludge}} + M_{\text{Loss}} \quad (1)$$

Where, M_{Inf} and M_{Eff} and M_{Sludge} represent the mass load (g/d) of a target androgen in the influent, effluent and excess sludge of the selected WWTP, respectively, the estimation methods are detailed in the supporting information. M_{Loss} represents the lost mass load (g/d) of a target compound due to adsorption or/and degradation in treatment units.

Based on equation (1), the lost mass load fraction (M_{Loss} %) for each androgen can be calculated according to the following equation:

$$M_{\text{Loss}} \% = (M_{\text{Inf}} - M_{\text{Eff}} - M_{\text{Sludge}}) / M_{\text{Inf}} \times 100\% \quad (2)$$

The mass fractions of each androgen in the effluent and excess sludge were calculated from $M_{\text{Eff}}/M_{\text{Inf}}\%$ and $M_{\text{Sludge}}/M_{\text{Inf}}\%$, respectively.

The removal rate of a target compound in aqueous phase is used to measure the removal efficiency, it can be calculated by the following equation:

$$R_{\text{Aqueous}} \% = (C_{\text{Inf-I}} - C_{\text{Eff-i}}) / C_{\text{Inf}} \times 100\% \quad (3)$$

Where, $C_{\text{Inf-i}}$ and $C_{\text{Eff-i}}$ represent the concentration (ng/L) of the target compound in the incoming and outgoing water of the selected treatment unit, respectively. C_{Inf} represents the concentration of target compound in the influent (ng/L); $R_{\text{Aqueous}}\%$ represents the aqueous removal efficiency of the target compound in the selected treatment unit.

2.5. Ecological risk assessment

The risk quotient (RQ) approach was applied in ecological risk assessment for androgens in surface water. For this method, RQs are calculated by dividing exposure estimates by the acute and chronic ecotoxicity values based on European Commission Technical Guidance Document by using equation (4) (EC, 2003):

$$RQ = \text{MEC}/\text{PNEC} \quad (4)$$

Where, MEC means the measured environmental concentration and PNEC represents the predicted no effect concentration of a chemical. According to the risk ranking criteria, $0.01 \leq RQ < 0.1$, $0.1 \leq RQ < 1$ and $RQ \geq 1$ indicate low risk, medium risk and high risk, respectively (Hernando et al., 2006). The PNEC value can be calculated using the aquatic acute median effective concentration (EC50) or chronic no observed effect concentration (NOEC) values of a chemical (EC, 2003). For those androgens detected in the receiving rivers, the obtained PNEC values are given in SI (Table S4). For the worst case scenario, we used the highest MEC values for the receiving environment of each plant.

3. Results

3.1. Concentrations of androgens in WWTPs

The range of concentrations, mean concentrations and median concentrations of all detected androgenic compounds in the water samples and sludge/sediment samples of all studied WWTPs are summarized in Table 2 and Table 3. As shown in Fig. 3, ten of fourteen target androgens were detected in influents of the ten WWTPs, with concentrations ranging from N.D. to 0.62 ng/L for MT, and from 30.2 to 4650 ng/L for ADD. Among the ten detected androgens in influents, natural androgens ADD, AED and TTR, synthetic androgens 17α-BOL and 17β-BOL could be found in all influents with their detection frequencies achieving 100% (Table 2). Other androgens such as EADR (N.D. to 751 ± 43.1 ng/L) and 17α-TBL (N.D. to 5.81 ± 1.35 ng/L) could also be detected in most studied influents (Table S5) with detection frequencies of 70% and 50%. The total concentration of all detected androgens in the ten influents ranged from 49.2 to 4960 ng/L, where ADD, EADR and AED contributing the most, accounting for 16.4% (Plant HY) to 91.5% (Plant DTS-1), 1.29% (Plant DTS-1) to 73.7% (Plant HY), and 4.88% (Plant DTS-1) to 17.6% (Plants MH), respectively. Besides, the synthetic androgen 17β-BOL also had relatively high concentrations ranging from 3.66 to 102 ng/L in the ten influents, accounting for 1.93% (Plant DTS-1) to 9.67% (Plant LB). There were only 3 androgens: natural steroids ADD (0.45–13.8 ng/L) and AED (N.D. to 5.13 ng/L), and synthetic one 17β-BOL (N.D. to 1.34 ng/L) were detected in the effluents (Table 2, and Table S5). Only ADD was found in all effluents. The concentrations of detected androgens in effluents are significantly lower than those in influents.

Androgens were also detected in the sewage from different process stages of the ten WWTPs, with natural ones ADD (N.D. to 2000 ng/L), AED (N.D. to 284 ng/L) and EADR (N.D. to 839 ng/L) being the dominant compounds (Tables S6-S15, Fig. S2). The detection frequency of synthetic androgen 17β-BOL was also relatively high, with its detected concentrations ranging from several ng/L to hundreds ng/L. In addition, the concentration distributions of ∑10 detected androgens varied among different WWTPs ranging from dozens to hundreds ng/L in the influents of XT and HJ to above 2500 ng/L in the influents of LJ and DTS-1 (Fig. S2).

The concentration levels (range, mean, median) of target androgens detected in the sludge samples from the ten WWTPs are summarized in Table 3, more concentration details given in

Table 2
Concentrations (ng/L) of 14 androgens in the water phase of every process stage in ten WWTPs and their receiving waters.

Compound	Abbrev.	Influent	Grit chamber	Anaerobic	Anoxic	Oxic	Secondary clarifier	Effluent	Pre-anoxic	MBR	UNITANK	Filtration	Receiving water	Detection frequency (%)
17 α -Boldenone	17 α -BOL	4.86–15.9 (8.26,7.89) ^a	ND-27.9 (9.43,7.56)	ND-11.7 (8.05,8.06)	ND-11.0 (10.6,10.7)	ND-9.61 (7.11,7.36)	N.D.	N.D.	N.D.	N.D.	N.D.	N.D.	ND-43.8 (5.53,4.03)	100
17 α -Trenbolone	17 α -TBL	ND-7.35 (3.95,3.46)	ND-5.43 (4.1,3.97)	ND-1.25 (1.02,0.96)	ND-1.94 (1.41,1.46)	ND-7.35 (4.29,4.81)	N.D.	N.D.	N.D.	N.D.	N.D.	N.D.	ND-0.89 (0.59,0.68)	60
17 β -Boldenone	17 β -BOL	3.54–119 (46.2,29.3)	ND-329 (66.1,29.8)	ND-31.0 (9.94,11.4)	ND-10.5 (10.4,10.5)	ND-119 (32.7,15.4)	N.D.	ND-1.34 (1.31,1.32)	ND-3.33 (2.18,3.2)	N.D.	1.29–1.40 (1.35,1.34)	N.D.	ND-75 (17.1,5.71)	100
17 β -Trenbolone	17 β -TBL	ND-2.56 (1.62,1.54)	ND-3.07 (2.21,2.07)	ND-3.86 (3.13,3.06)	ND-4.10 (3.75,3.88)	ND-6.59 (2.99,2.1)	N.D.	N.D.	N.D.	N.D.	N.D.	N.D.	N.D.	20
19-Nortestosterone	19-NT	N.D. ^b	N.D.	N.D.	N.D.	N.D.	N.D.	N.D.	N.D.	N.D.	N.D.	N.D.	N.D.	0
4-Hydroxy-androst-4-ene-17-dione	4-OHA	N.D.	N.D.	N.D.	N.D.	N.D.	N.D.	N.D.	N.D.	N.D.	N.D.	N.D.	N.D.	0
5 α -Dihydrotestosterone	5 α -DHT	N.D.	N.D.	N.D.	N.D.	N.D.	N.D.	N.D.	N.D.	N.D.	N.D.	N.D.	N.D.	0
Androsta-1,4-diene-3,17-dione	ADD	30.2–4650 (834,224)	ND-1460 (541,293)	ND-72.0 (12.7,4.46)	ND-55.4 (12.0,4.20)	ND-2000 (175,4.19)	ND-5.92 (3.18,3.4)	0.45–13.8 (3.49,2.70)	ND-17.7 (16.1,16.3)	2.3–2.42 (2.37,2.4)	3.95–4.83 (4.28,4.08)	0.45–0.45 (0.45,0.45)	2.26–548 (73.6,15.5)	100
Androsterone	ADS	N.D.	N.D.	N.D.	N.D.	N.D.	N.D.	N.D.	N.D.	N.D.	N.D.	N.D.	N.D.	0
4-Androstene-3,17-dione	AED	6.21–284 (100,80.3)	ND-239 (92.3,85.3)	2.57–41.4 (8.74,3.92)	ND-27.4 (7.11,3.95)	ND-284 (28.4,3.92)	ND-4.56 (3.19,3.07)	ND-5.13 (3.53,3.54)	ND-9.55 (9.40,9.47)	2.96–2.99 (2.97,2.96)	2.45–2.75 (2.55,2.46)	2.06–2.18 (2.11,2.10)	1.89–197 (24.0,4.80)	100
Epi-androsterone	EADR	ND-779 (371,430)	ND-839 (402,428)	ND-321 (290,282)	ND-406 (373,382)	ND-710 (555,526)	N.D.	N.D.	ND-22.1 (13.7,10.3)	N.D.	N.D.	N.D.	ND-680 (246,201)	70
Methyl testosterone	MT	ND-0.62 (0.49,0.49)	ND-0.48 (0.48,0.48)	N.D.	N.D.	ND-0.62 (0.62,0.62)	N.D.	N.D.	N.D.	N.D.	N.D.	N.D.	ND-0.38 (0.33,0.33)	20
Stanozolol	S	ND-29.9 (21.2,21.1)	ND-26.8 (19.3,18.7)	ND-2.41 (2.19,2.29)	ND-6.70 (6.56,6.7)	N.D.	N.D.	N.D.	N.D.	N.D.	N.D.	N.D.	N.D.	20
Testosterone	TTR	ND-29.7 (12.4,10.1)	ND-55.3 (14.9,12)	ND-6.98 (2.80,1.80)	ND-7.33 (3.02,1.02)	ND-24.6 (7.21,3.83)	N.D.	ND-3.57 (3.14,3.11)	ND-1.54 (1.45,1.40)	N.D.	N.D.	N.D.	ND-31.9 (7.64,1.95)	100
n ^c		10	9	9	8	9	8	10	2	1	1	1	18	

^a Range (mean, median), sample numbers for each stage are three times the numbers of that process stage.

^b N.D.: not detected.

^c n: the numbers of process stages among ten WWTPs or the numbers of sampling sites for receiving water.

Table 3
Concentrations (ng/g) of 14 androgens in the sludge of every process stage of ten WWTPs and the sediment of their receiving rivers.

Compound	Abbrev.	Anaerobic	Anoxic	Oxic	Return sludge	Excess sludge	Pre-anoxic	UNITANK	Receiving sediment	Detection frequency (%)
17 α -Boldenone	17 α -BOL	N.D. ^a	N.D.	N.D.	N.D.	N.D.	N.D.	N.D.	N.D.	0
17 α -Trenbolone	17 α -TBL	N.D.	N.D.	N.D.	N.D.	N.D.	N.D.	N.D.	N.D.	0
17 β -Boldenone	17 β -BOL	ND-1.86 (1.41,1.37) ^b	ND-2.05 (1.33,1.29)	ND-1.74 (1.61,1.67)	ND-1.64 (1.58,1.56)	ND-1.35 (1.23,1.26)	N.D.	N.D.	ND-1.03 (0.95,0.95)	50
17 β -Trenbolone	17 β -TBL	N.D.	N.D.	N.D.	N.D.	N.D.	N.D.	N.D.	N.D.	0
19-Nortestosterone	19-NT	N.D.	N.D.	N.D.	N.D.	N.D.	N.D.	N.D.	N.D.	0
4-Hydroxy-androst-4-ene-17-dione	4-OHA	N.D.	N.D.	N.D.	N.D.	N.D.	N.D.	N.D.	N.D.	0
5 α -Dihydrotestosterone	5 α -DHT	N.D.	N.D.	N.D.	N.D.	N.D.	N.D.	N.D.	N.D.	0
Androsta-1,4-diene-3,17-dione	ADD	ND-43.0 (8.25,4.03)	1.45–19.2 (5.13,3.39)	1.58–11.1 (4.88,4.40)	ND-18.6 (5.64,3.43)	ND-24.6 (10.4,8.11)	ND-3.42 (3.28,3.22)	8.07–8.89 (8.43,8.32)	ND-24 (4.9,2.53)	100
Androsterone	ADS	N.D.	N.D.	N.D.	N.D.	N.D.	N.D.	N.D.	N.D.	0
4-Androstene-3,17-dione	AED	2.23–42.7 (9.92,5.18)	2.22–23.7 (8.20,4.72)	2.06–27.3 (7.72,4.93)	2.53–17.1 (6.75,3.55)	2.26–23.9 (7.50,4.63)	2.39–3.76 (3.15,3.19)	14.9–16.2 (15.4,15.1)	1.42–33.9 (6.46,2.7)	100
Epi-androsterone	EADR	ND-416 (116,98.7)	10.1–441 (110,79.9)	7.26–421 (86,56.5)	ND-369 (108,73.6)	ND-506 (127,91.0)	9.99–62.6 (33.7,32.2)	190–221 (208,212)	ND-129 (87,108)	100
Methyl testosterone	MT	ND-0.72 (0.69,0.72)	ND-0.73 (0.67,0.66)	ND-0.72 (0.66,0.68)	ND-0.70 (0.67,0.68)	ND-0.72 (0.64,0.60)	N.D.	N.D.	ND-1.24 (1.19,1.19)	10
Stanozolol	S	N.D.	N.D.	N.D.	N.D.	N.D.	N.D.	N.D.	N.D.	0
Testosterone	TTR	0.37–3.92 (1.68,1.25)	0.46–2.68 (1.49,1.22)	0.34–4.24 (1.45,0.97)	0.44–3.01 (1.42,1.28)	0.29–2.42 (1.08,1.14)	0.37–1.30 (0.82,0.81)	1.32–1.42 (1.38,1.41)	ND-4.81 (1.63,0.73)	100
n ^c		9	8	9	7	9	2	1	17	

^a N.D.: not detected.

^b Range (mean, median), sample numbers for each stage are three times the numbers of that process stage.

^c n: the numbers of process stages among ten WWTPs or the numbers of sampling sites for receiving water.

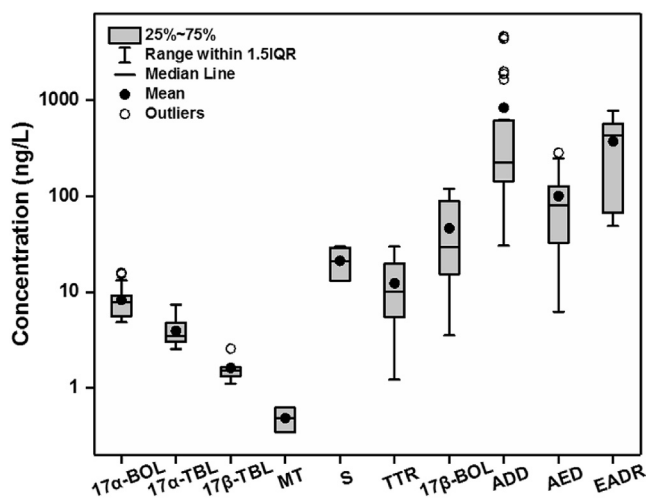

Fig. 3. Boxplots for concentration distributions of 10 detected androgens in the influents of ten WWTPs. Vertical axis is in log₁₀ scale. AED: 4-Androstene-3,17-dione; ADD: Androsta-1,4-diene-3,17-dione; EADR: Epi-androsterone; TTR: Testosterone; 17 α -BOL: 17 α -Boldenone; 17 β -BOL: 17 β -Boldenone; MT: Methyl testosterone; 17 α -TBL: 17 α -Trenbolone; 17 β -TBL: 17 β -Trenbolone; S: Stanozolol.

Tables S6–S15, and Fig. S3. Only six androgens were detected, including natural androgens ADD (N.D. ~ 43.0 ng/g), AED (2.06–42.7 ng/g), EADR (N.D. ~ 506 ng/g) and TTR (0.29–4.24 ng/g), synthetic androgens 17 β -BOL (N.D. ~ 2.05 ng/g) and MT (N.D. ~ 0.70 ng/g). EADR was present in all sludge samples from the ten WWTPs (except the excess sludge of XT WWTP and anoxic sludge of DTS-2 WWTP), with average detected concentrations ranging from 7.26 to 506 ng/g. Besides, natural androgens ADD and AED were also detected in the sludge samples of all ten WWTPs

with relatively high concentrations, ranging from 1.58 to 43.0 ng/g, and from 1.42 to 42.7 ng/g, respectively.

3.2. Removal of androgens in the WWTPs

The aqueous phase removal rates for each detected androgen and all androgens in each WWTP are shown in Table 4. For most detected androgens, they were significantly eliminated with final removal rates exceeding 95%. The WWTPs with A²/O (DTS-1, and LB), MBR (JX) and Carrousel 2000 Oxidation ditch (HJ) showed better efficiencies in removing androgens.

The mass loads of androgens in influents and effluents of the ten WWTPs were estimated according to the mass balance equations (Tables S16–S25, Fig. S4). For most target androgens such as TTR, 17 α -BOL and 17 α -TBL, their mass loss percentages were over 95% with final effluent concentrations below their detection limits. For those that were not detected in the influents of some WWTPs but appeared in the subsequent process sections or activated sludge, their mass losses were negative, for example 17 α -TBL and 17 β -TBL in Plant HY, EADR in Plants MH, HJ and XT. This may be related to the de-conjugation of some conjugated androgens (Gomes et al., 2009) or transformation of other structural analogs (Arioli et al., 2008; Blackwell et al., 2015), or due to their relatively stronger adsorbability in activated sludge (Khan et al., 2009). EADR, AED and 17 β -BOL were easily adsorbed in sludge, resulting high aqueous removal. The removal of target androgens in all WWTPs was mainly through microbial degradation. On the whole, a majority of detected androgens were eliminated significantly.

3.3. Concentrations of androgens in receiving rivers

As displayed in Table 2 and Fig. 4, eight androgens that were detected in WWTPs were also found in the surface water samples of receiving rivers, with concentrations higher than in the effluents

Table 4
Aqueous removal rates (%) for androgens in the ten WWTPs.

	XT	DTS-1	DTS-3	LB	JX	HJ	LD	LJ	MH	HY
17 α -BOL	100.0	100.0	100.0	100.0	100.0	100.0	100.0	100.0	100.0	100.0
17 α -TBL	N. A. ^a	N. A.	N. A.	100.0	100.0	N. A.	100.0	100.0	100.0	N. A.
17 β -BOL	100.0	100.0	100.0	100.0	100.0	100.0	97.67	100.0	100.0	100.0
17 β -TBL	N. A.	N. A.	N. A.	100.0	100.0	N. A.	N. A.	N. A.	N. A.	N. A.
ADD	98.60	99.92	99.42	99.56	99.86	99.66	98.63	98.50	94.84	95.82
AED	79.54	98.44	90.60	97.28	98.86	100.0	97.60	96.58	93.31	89.92
EADR	N. A.	100.0	100.0	100.0	100.0	N. A.	100.0	100.0	N. A.	100.0
MT	N. A.	N. A.	N. A.	N. A.	N. A.	100.0	N. A.	100.0	N. A.	N. A.
S	N. A.	N. A.	N. A.	N. A.	N. A.	N. A.	N. A.	100.0	N. A.	100.0
TTR	100.0	100.0	100.0	100.0	100.0	100.0	100.0	100.0	100.0	100.0
Total Androgen	96.36	99.85	98.98	99.41	99.81	99.77	99.12	99.30	95.24	98.82

notn.

^a N. A.: not available, when a target androgen was not detected in the influent of a WWTP, its removal rate in that WWTP was then expressed as N. A.

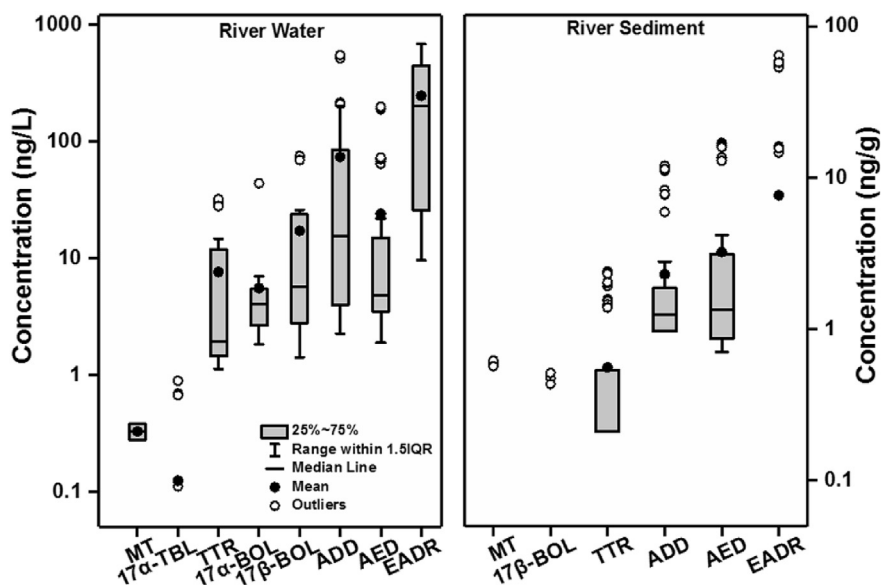

Fig. 4. Boxplots for concentration distributions of detected androgens in the water and sediment of the receiving rivers. Vertical axis is in log₁₀ scale. AED: 4-Androstene-3,17-dione; ADD: Androsta-1,4-diene-3,17-dione; EADR: Epi-androsterone; TTR: Testosterone; 17 α -BOL: 17 α -Boldenone; 17 β -BOL: 17 β -Boldenone; MT: Methyl testosterone; 17 α -TBL: 17 α -Trenbolone.

(also see Tables S6–S15). The outstanding examples are those natural androgens, such as ADD (2.26–548 ng/L), AED (1.89–197 ng/L) and EADR (N.D. ~ 680 ng/L). It should be noted that EADR was not found in the effluents, but detected at high concentrations in the rivers. Synthetic androgens 17 β -BOL and 17 α -BOL also had relatively high detected concentrations up to 75 ng/L and 43.8 ng/L. Six androgens detected in activated sludge were also found in the river sediments, but with relatively lower concentrations from several ng/g to dozens ng/g, except for EADR with its concentration up to 129 ng/g.

3.4. Risk assessment

The RQs for the detected androgens in the receiving rivers were calculated based on their estimated PNEC values and the highest MEC values for each site as the worst case scenario (Table S4, Table S26). As shown in Fig. 5, the RQs for AED and ADD in the receiving rivers of Plants XT, HJ and LB were over 1, indicating high ecological risks. The highest RQs for 17 β -TBL and MT were 68.2 and 3.67 despite their low detected concentrations. Medium risks were found for TTR in two rivers (Plants HJ, and LB), with its RQs more than 0.1. For anabolic androgen 17 β -BOL, even though its

concentration in receiving river was up to 73.34 ng/L, its RQ values were less than 0.01, indicating minimal risks.

4. Discussion

4.1. Occurrence and fate of androgens in WWTPs

The results from the present study showed the presence of ten androgens in WWTPs and variations in concentration levels among the ten WWTPs as well as significant removals after various treatment processes (Table 2). Natural androgens ADD, AED, EADR and TTR were frequently detected in the influents, while ADS was not found in influents of the ten WWTPs (Fig. 3). In contrast, ADS was reported in WWTP influents in some previous studies (Chang et al., 2011; Fan et al., 2011), which may be related to the differences in regional weather conditions as those WWTPs are located in North China with cold weather conditions comparing to the subtropical weather in the present study. Our laboratory preliminary degradation test showed rapid loss of ADS in sewage within 8 h (Fig. S5). Similar concentrations for AED, EADR and TTR (Table S27) have been reported in previous studies (Chang et al., 2011; Fan et al., 2011; Fernandez et al., 2007; Huang et al., 2014),

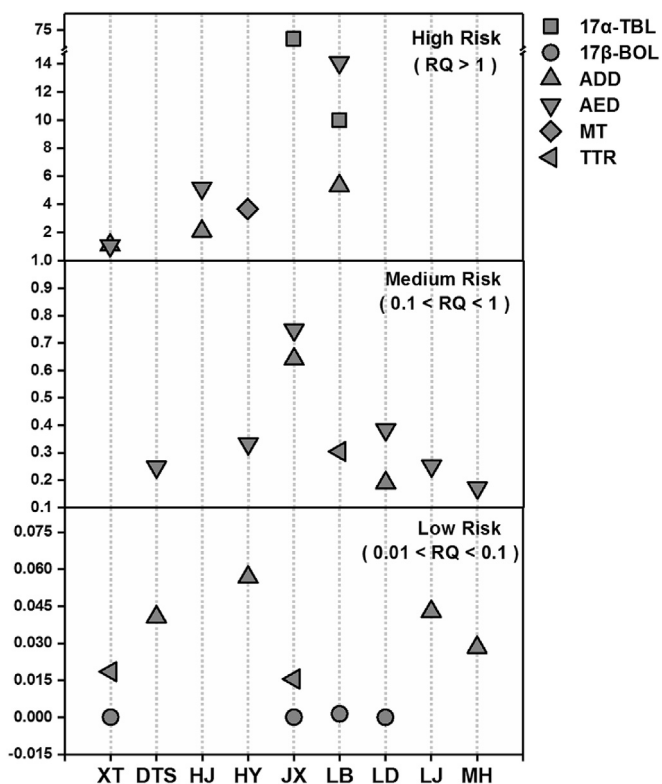

Fig. 5. Risk assessment of six androgens in the receiving rivers based on their estimated risk quotients (RQs). AED: 4-Androstene-3,17-dione; ADD: Androsta-1,4-diene-3,17-dione; TTR: Testosterone; 17β-BOL: 17β-Boldenone; MT: Methyl testosterone; 17α-TBL: 17α-Trenbolone.

however, ADD was not included in those studies. The concentration levels found for EADR and TTR in the WWTP influents of the present study were also consistent with the estimated concentrations by using the daily human excretion data and the service population of each WWTP (Fig. S6).

Natural androgen ADD occupied a dominant position among those detected androgens in influents accounting for more than 60% of total androgen concentrations. This is consistent with our previous study (Liu et al., 2012a). Natural androgen AED also showed much higher measured concentrations in influents than the predicted values (Fig. S5). Previous studies reported that plant sterols such as β-sitosterol could be transferred to AED and ADD after a range of processes controlled by microorganisms (Jenkins et al., 2004). In addition, naturally occurring progesterone could serve as the precursor for these two androgens (Carson et al., 2008; Janeczko and Skoczowski, 2005). In addition, AED could be interchanged with other androgens (Arioli et al., 2008). This explains relatively high concentrations of AED and ADD in the wastewater and river water observed in the present study.

High efficiencies of androgen removal were found in nearly all ten WWTPs. In general, the synthetic androgens were found easier to be removed when compared to the natural androgens. In Plants DTS-1 and LB with A2/O process, Plant JX with MBR and Plant HJ with the Carrousel 2000 Oxidation ditch process, biochemical processes with anaerobic-anoxic-oxic order showed better efficiencies in removing androgens than the other processes. The main removal mechanisms for the steroids in WWTPs include sorption, degradation and advanced oxidation processes (Liu et al., 2009), while loss from volatilization should be considered negligible based on their physiochemical properties. From mass balance analysis in the present study (Fig. S4), it can be found that the removal of

androgens from the ten WWTPs mainly occurred in the biochemical units and mainly via biodegradation, with little contribution from the subsequent oxidation processes.

4.2. Occurrence and risks of androgens in rivers

The results of the present study showed the presence of eight androgens in the receiving rivers, with their concentrations higher than those in the WWTP effluents (Table 2, Fig. 4). For the natural androgens, they can be naturally produced and released by aquatic organisms, and some androgens could be degradation or conversion products of other similar structural substances (Arioli et al., 2010; Jenkins et al., 2004). This could be one possible cause for their higher concentrations in the receiving rivers than in the effluents. The highest concentration in all rivers was found for EADR, while ADD was still one of the dominant androgens and detected in all ten receiving rivers. These androgens were also detected in surface waters in some previous studies with similar concentration ranges (Table S28) (Chang et al., 2008, 2011; Yamamoto et al., 2006; Liu et al., 2015), indicating the ubiquitous presence of androgens in the aquatic environment impacted by wastewater.

High risks were found in five rivers based on the simple risk quotients of androgens (Fig. 5). The negative impacts of androgens on fish have been reported (Barbosa et al., 2008; DeQuattro et al., 2015; Robinson et al., 2017). DeQuattro et al. (2015) indicated that AED had the potential to disrupt endocrine function in male fathead minnows after 26-days exposure with concentrations at 4.5 ng/L, 74 ng/L, and 700 ng/L. Barbosa et al. (2008) reported a decreasing spawning rate and reproductive capacity of *Daphnia magna* after a long-term exposure to water containing 0.31–2.48 mg/L of TTR, and also noted an increasing mortality of *Daphnia magna* neonates after a long-term 4-OHA exposure at 0.84 mg/L. Ankley et al. (2001) found that fathead minnows produced an increase in vitellogenin production in both males and females after a 12-day exposure to MT. Blázquez et al. (2001) reported that 10 and 20 mg/kg MT (dietary exposure) would increase the occurrence of intratestes oocytes in European sea bass. Sone et al. (2005) also confirmed that adult mosquitofish exposed to MT (0.1–10 μg/L) or 17β-TBL (1–10 μg/L) after 28 d would induced masculinization of adult females and stimulated precocious spermatogenesis in the testes of males and the formation of ovotestes in females. Furthermore, Ankley et al. (2003) found that the fecundity of fathead minnow was significantly reduced by exposure to 17β-TBL at concentrations higher than 0.027 μg/L for 21 days. After a long-term exposure to 17α-TBL, Robinson et al. (2017) observed adverse effects on fecundity of the fathead minnow occurred when the concentration of 17α-TBL reached 120 ng/L. In fact, a field survey found serious androgenic effects in mosquitofish at urban streams of Guangzhou (Wen et al., 2013). Hence the androgens detected in the receiving rivers could pose ecological risks to aquatic organisms. It is noteworthy that this was a simple risk assessment with limited toxicity data; the risks for each compound may change with more toxicity data available in the future. A further research is needed to understand specific biological effects in the receiving environments.

5. Conclusion

The occurrence of 14 androgens was investigated in ten WWTPs and their receiving rivers. Ten out of fourteen androgens were detected in wastewaters and six androgens were found in activated sludge of the WWTPs. Natural androgens with relatively high concentrations are ubiquitous in both the WWTPs and the receiving rivers. The WWTPs with different treatment technologies showed good removals for these androgens, mainly through

biological degradation/transformation processes in the biochemical units. Despite the high removal efficiency in WWTPs, eight androgens were still detected in the receiving rivers, and some had higher concentrations than those in the effluents, suggesting other sources for the androgens in the rivers. Such high concentration levels of androgens could pose ecological risks to aquatic organisms like fish. Further research is needed to understand the origin and ecological effects of androgens in the aquatic environments.

Acknowledgements

The authors would like to acknowledge the financial support from the National Science Foundation of China (NSFC 41473105, U1401235 and 41303077) and National Water Pollution Control Program of China (2014ZX07206-005). Thanks also to Guangzhou Sewage Purification Company for their assistance in the sample collection. This is a Contribution No. IS 2516 from GIG CAS.

Appendix A. Supplementary data

Supplementary data related to this article can be found at <https://doi.org/10.1016/j.chemosphere.2018.02.144>.

References

- Ankley, G.T., Hensen, K.M., Kahl, M.D., Korte, J.J., Makynen, E.A., 2001. Description and evaluation of a short-term reproductive test with the fathead minnow (*Pimephales promelas*). *Environ. Toxicol. Chem.* 20, 1276–1290.
- Ankley, G.T., Jensen, K.M., Makynen, E.A., Kahl, M.D., Korte, J.J., Hornung, M.W., Henry, T.R., Denny, J.S., Leino, R.L., Wilson, V.S., Cardon, M.C., Hartig, P.C., Gray, L.E., 2003. Effects of the androgenic growth promoter 17 β -trenbolone on fecundity and reproductive endocrinology of the fathead minnow. *Environ. Toxicol. Chem.* 22, 1350–1360.
- Arioli, F., Fidani, M., Casati, A., Fracchiolla, M.L., Pompa, G., 2010. Investigation on possible transformations of cortisol, cortisone and cortisol glucuronide in bovine faecal matter using liquid chromatography-mass spectrometry. *Steroids* 75, 350–354.
- Arioli, F., Gavinelli, M.P., Fracchiolla, M.L., Casati, A., Fidani, M., Ferrer, E., Pompa, G., 2008. Evaluation of boldenone formation and related steroids transformations in veal faeces by liquid chromatography/tandem mass spectrometry. *Rapid Commun. Mass Spectrom.* 22, 217–223.
- Barbosa, I.R., Nogueira, A.J.A., Soares, A.M.V.M., 2008. Acute and chronic effects of testosterone and 4-hydroxyandrostenedione to the crustacean *Daphnia magna*. *Ecotoxicol. Environ. Saf.* 71, 757–764.
- Blackwell, B.R., Johnson, B.J., Buser, M.D., Cobb, G.P., Smith, P.N., 2015. Transformation kinetics of trenbolone acetate metabolites and estrogens in urine and feces of implanted steers. *Chemosphere* 138, 901–907.
- Blázquez, M., Felip, A., Zanuy, S., Carrillo, M., Piferrer, F., 2001. Critical period of androgen-inducible sex differentiation in a teleost fish, the European sea bass. *J. Fish. Biol.* 58, 342–358.
- Carson, J.D., Jenkins, R.L., Wilson, E.M., Howell, W.M., Moore, R., 2008. Naturally occurring progesterone in loblolly pine (*Pinus taeda* L.): a major steroid precursor of environmental androgens. *Environ. Toxicol. Chem.* 27, 1273–1278.
- Chang, H., Wan, Y., Hu, J., 2009. Determination and source apportionment of five classes of steroid hormones in urban rivers. *Environ. Sci. Technol.* 43, 7691–7698.
- Chang, H., Wan, Y., Wu, S., Fan, Z., Hu, J., 2011. Occurrence of androgens and progestogens in wastewater treatment plants and receiving river waters: comparison to estrogens. *Water Res.* 45, 732–740.
- Chang, H., Wu, S., Hu, J., Asami, M., Kunikane, S., 2008. Trace analysis of androgens and progestogens in environmental waters by ultra-performance liquid chromatography-electrospray tandem mass spectrometry. *J. Chromatogr. A* 1195 (1–2), 44–51.
- Christiansen, T., Korsgaard, B., Jespersen, A., 1998. Effects of nonylphenol and 17 beta-oestradiol on vitellogenin synthesis, testicular structure and cytology in male eelpout *Zoarces viviparus*. *J. Exp. Biol.* 201, 179–192.
- Clesceri, L., Greenberg, A., Eaton, A., 2001. Standard Methods for the Examination of Water and Wastewater, twentieth ed. APHA, Washington, DC.
- Combalbert, S., Hernandez-Raquet, G., 2010. Occurrence, fate, and biodegradation of estrogens in sewage and manure. *Appl. Microbiol. Biotechnol.* 86, 1671–1692.
- DeQuattro, Z.A., Hemming, J.D.C., Barry, T.P., 2015. Effects of androstenedione exposure on fathead minnow (*Pimephales promelas*) reproduction and embryonic development. *Environ. Toxicol. Chem.* 34, 2549–2554.
- EC (European Commission), 2003. In: Commission E (Ed.), European Commission Technical Guidance Document in Support of Commission Directive 93/67/EEC on Risk Assessment for New Notified Substances and Commission Regulation No 1488/94 on Risk Assessment for Existing Substances, Part II. Office for official publications of the European Communities, Luxembourg.
- Fan, Z., Wu, S., Chang, H., Hu, J., 2011. Behaviors of glucocorticoids, androgens and progestogens in a municipal sewage treatment plant: comparison to estrogens. *Environ. Sci. Technol.* 45, 2725–2733.
- Fernandez, M.P., Buchanan, I.D., Ikonomou, M.G., 2008. Seasonal variability of the reduction in estrogenic activity at a municipal WWTP. *Water Res.* 42, 3075–3081.
- Fernandez, M.P., Ikonomou, M.G., Buchanan, I., 2007. An assessment of estrogenic organic contaminants in Canadian wastewaters. *Sci. Total Environ.* 373, 250–269.
- Golden, R.J., Noller, K.L., Titus Ernstoff, L., Kaufman, R.H., Mittendorf, R., Stillman, R., Reese, E.A., 1998. Environmental endocrine modulators and human health: an assessment of the biological evidence. *Crit. Rev. Toxicol.* 28, 109–227.
- Gomes, R.L., Meredith, W., Snape, C.E., Septhorn, M.A., 2009. Analysis of conjugated steroid androgens: deconjugation, derivatization and associated issues. *J. Pharmaceut. Biomed.* 49, 1133–1140.
- Heidler, J., Halden, R.U., 2008. Meta-analysis of mass balances examining chemical fate during wastewater treatment. *Environ. Sci. Technol.* 42, 6324–6332.
- Hernando, M.D., Mezcuca, M., Fernández-Alba, A.R., Barceló, D., 2006. Environmental risk assessment of pharmaceutical residues in wastewater effluents, surface waters and sediments. *Talanta* 69, 334–342.
- Hotchkiss, A.K., Lambright, C.S., Ostby, J.S., Parks-Saldutti, L., Vandenberg, J.G., Gray, L.E., 2007. Prenatal testosterone exposure permanently masculinizes anogenital distance, nipple development, and reproductive tract morphology in female Sprague-Dawley rats. *Toxicol. Sci.* 96, 335–345.
- Hotchkiss, A.K., Nelson, R.J., 2007. An environmental androgen, 17 β -trenbolone, affects delayed-type hypersensitivity and reproductive tissues in male mice. *J. Toxicol. Environ. Health A* 70, 138–140.
- Hou, L.P., Yang, Y., Shu, H., Ying, G.G., Zhao, J.L., Fang, G.Z., Xin, L., Shi, W.J., Ya, L., Cheng, X.M., 2018. Masculinization and reproductive effects in western mosquitofish (*Gambusia affinis*) after long-term exposure to androstenedione. *Ecotoxicol. Environ. Saf.* 147, 509–515.
- Huang, B., Li, X.M., Sun, W.W., Ren, D., Li, X., Li, X.N., Liu, Y., Li, Q., Pan, X., 2014. Occurrence, removal, and fate of progestogens, androgens, estrogens, and phenols in six sewage treatment plants around Dianchi Lake in China. *Environ. Sci. Pollut. Res.* 21, 12898–12908.
- Huang, G.Y., Liu, Y.S., Chen, X.W., Liang, Y.Q., Liu, S.S., Yang, Y.Y., Hu, L.X., Shi, W.J., Tian, F., Zhao, J.L., Chen, J., Ying, G.G., 2016. Feminization and masculinization of western mosquitofish (*Gambusia affinis*) observed in rivers impacted by municipal wastewaters. *Sci. Rep.* 6, 20884.
- Janecko, A., Skoczowski, A., 2005. Mammalian sex hormones in plants. *Folia Histochem. Cytobiol.* 43, 71–79.
- Jenkins, R., Angus, R.A., McNatt, H., Howell, W.M., Kemppainen, J.A., Kirk, M., Wilson, E.M., 2001. Identification of androstenedione in a river containing paper mill effluent. *Environ. Toxicol. Chem.* 20, 1325–1331.
- Jenkins, R.L., Wilson, E.M., Angus, R.A., Howell, W.M., Kirk, M., Moore, R., Nance, M., Brown, A., 2004. Production of androgens by microbial transformation of progesterone in vitro: a model for androgen production in rivers receiving paper mill effluent. *Environ. Health Perspect.* 112, 1508–1511.
- Kang, I.J., Yokota, H., Oshima, Y., Tsuruda, Y., Shimasaki, Y., Honjo, T., 2008. The effects of methyltestosterone on the sexual development and reproduction of adult medaka (*Oryzias latipes*). *Aquat. Toxicol.* 87, 37–46.
- Khan, B., Qiao, X., Lee, L.S., 2009. Stereoselective sorption by agricultural soils and liquid-liquid partitioning of trenbolone (17 α and 17 β) and trenbolone. *Environ. Sci. Technol.* 43, 8827–8833.
- Kolpin, D.W., Furlong, E.T., Meyer, M.T., Thurman, E.M., Zaugg, S.D., Barber, L.B., Buxton, H., 2002. Pharmaceuticals, hormones, and other organic wastewater contaminants in U.S. streams, 1999–2000: a national reconnaissance. *Environ. Sci. Technol.* 36, 1202–1211.
- Laurence, S.S., Mordechai, S., 2003. Naturally produced steroid hormones and their release into the environment. *Pure Appl. Chem.* 75 (11–12), 1859–1871.
- Leusch, F.D.L., Khan, S.J., Gagnon, M.M., Quayle, P., Trinh, T., Coleman, H., Rawson, C., Chapman, H., 2014. Assessment of wastewater and recycled water quality: a comparison of lines of evidence from in vitro, in vivo and chemical analyses. *Water Res.* 50, 420–431.
- Liu, S., Chen, H., Zhou, G.J., Liu, S.S., Yue, W.Z., Yu, S., Sun, K., Cheng, H.F., Ying, G.G., Xu, X.R., 2015. Occurrence, source analysis and risk assessment of androgens, glucocorticoids and progestagens in the Hailing Bay region. *South China Sea. Sci. Total Environ.* 536, 99–107.
- Liu, S., Ying, G.G., Zhao, J.L., Chen, F., Yang, B., Zhou, L.J., Lai, H.J., 2011. Trace analysis of 28 steroids in surface water, wastewater and sludge samples by rapid resolution liquid chromatography-electrospray ionization tandem mass spectrometry. *J. Chromatogr. A* 1218, 1367–1378.
- Liu, S., Ying, G.G., Zhao, J.L., Zhou, L.J., Yang, B., Chen, Z.F., Lai, H.J., 2012a. Occurrence and fate of androgens, estrogens, glucocorticoids and progestagens in two different types of municipal wastewater treatment plants. *J. Environ. Monit.* 14, 482–491.
- Liu, S., Ying, G.G., Zhou, L.J., Zhang, R.Q., Chen, Z.F., Lai, H.J., 2012b. Steroids in a typical swine farm and their release into the environment. *Water Res.* 46, 3754–3768.
- Liu, Z.H., Kanjo, Y., Mizutani, S., 2009. Removal mechanisms for endocrine disrupting compounds (EDCs) in wastewater treatment - physical means, biodegradation, and chemical advanced oxidation: a review. *Sci. Total Environ.* 407, 731–748.

- Orlando, E.F., Kolok, A.S., Binzick, G.A., Gates, J.L., Horton, M.K., Lambright, C.S., Gray, L.E., Soto, A.M., Guillette, Louis J., 2004. Endocrine-Disrupting effects of cattle feedlot effluent on an aquatic sentinel species, the fathead minnow. *Environ. Health Perspect.* 112, 353–358.
- Pelley, J., 2003. Estrogen knocks out fish in whole-lake experiment. *Environ. Sci. Technol.* 37, 313A.
- Penatti, C.A., Porter, D.M., Henderson, L.P., 2009. Chronic exposure to anabolic androgenic steroids alters neuronal function in the mammalian forebrain via androgen receptor- and estrogen receptor-mediated mechanisms. *J. Neurosci.* 29, 12484–12496.
- Radl, V., Pritsch, K., Munch, J.C., Schloter, M., 2005. Structural and functional diversity of microbial communities from a lake sediment contaminated with trenbolone, an endocrine-disrupting chemical. *Environ. Pollut.* 137, 345–353.
- Robinson, J.A., Staveley, J.P., Constantine, L., 2017. Reproductive effects on freshwater fish exposed to 17 α -trenbolone and 17 α -estradiol. *Environ. Toxicol. Chem.* 36, 636–644.
- Sone, K., Hinago, M., Itamoto, M., Katsu, Y., Watanabe, H., Urushitani, H., 2005. Effects of an androgenic growth promoter 17 β -trenbolone on masculinization of Mosquitofish (*Gambusia affinis affinis*). *Gen. Comp. Endocrinol.* 143, 151–160.
- Soto, A.M., Calabro, J.M., Prechtel, N.V., Yau, A.Y., Orlando, E.F., Daxenberger, A., Kolok, A.S., Guillette, L.J., Le, B.B., Lange, I.G., Sonnenschein, C., 2003. Androgenic and estrogenic activity in water bodies receiving cattle feedlot effluent in eastern Nebraska, USA. *Environ. Health Perspect.* 112, 346–352.
- Ternes, T.A., Kreckel, P., Mueller, J., 1999a. Behaviour and occurrence of estrogens in municipal sewage treatment plants—II. Aerobic batch experiments with activated sludge. *Sci. Total Environ.* 225 (1–2), 91–99.
- Ternes, T.A., Stumpf, M., Mueller, J., Haberer, K., Wilken, R.D., Servos, M., 1999b. Behavior and occurrence of estrogens in municipal sewage treatment plants—I. Investigations in Germany, Canada and Brazil. *Sci. Total Environ.* 225 (1–2), 81–90.
- Tyler, C.R., Jobling, S., Sumpter, J.P., 1998. Endocrine disruption in wildlife: a critical review of the evidence. *Crit. Rev. Toxicol.* 28, 319–361.
- Vulliet, E., Cren-Olivé, C., Grenier-Loustalot, M., 2011. Occurrence of pharmaceuticals and hormones in drinking water treated from surface waters. *Environ. Chem. Lett.* 9, 103–114.
- Wen, R., Xie, Y., Wan, C., Fang, Z., 2013. Estrogenic and androgenic effects in mosquitofish (*Gambusia affinis*) from streams contaminated by municipal effluent in Guangzhou, China. *Aquat. Toxicol.* 132–133, 165–172.
- Yamamoto, A., Kakutani, N., Yamamoto, K., Kamiura, T., Miyakoda, H., 2006. Steroid hormone profiles of urban and tidal rivers using LC/MS/MS equipped with electrospray ionization and atmospheric pressure photoionization sources. *Environ. Sci. Technol.* 40, 4132–4137.
- Ying, G.G., Kookana, R.S., Ru, Y.J., 2002. Occurrence and fate of hormone steroids in the environment. *Environ. Int.* 28, 545–551.